

# **4000ATP** Automatic Tray Packer

Ideal for loose or pre-packed groups of bottles, cans and jars, this ergonomically designed tray packer tightly forms a tray around product to create stable packs with minimum material. It meets all sanitary and food industry requirements with stainless steel, fall-through construction.



### **Quick-change Product Separators**



Quick-change feature allows for quick changeover without removing chains.

### **Quick Changeover**



Quick and accurate changeover takes as little as 20 to 30 minutes with locally hung tools.

### **Oscillating Product Laner**



Two-axis oscillating product laner conditions bulk product infed into lanes.

# 4000ATP Automatic Tray Packer

## A little about Serpa Packaging:

Each 4000ATP is customized to your specific needs. We work hard to ensure that you get the best design possible for your casepacking needs. In order to achieve this, we must have a lot of innovative capability. That's why our largest Investment at Serpa Packaging Solutions is in engineering. Our engineers test, debug, and prove every design. After your 4000ATP is installed, they monitor your satisfaction by providing you with maintenance and technical support.

## Standard Features:

- Small footprint
- Digital gauges and dials with pointers for changeover
- Gentle product handling
- User-friendly control panel with graphical diagnostic display
- Smooth, quiet and safe operation
- Full access doors make maintenance easy
- Low-height ergonomic magazine
- Online factory modem support available
- Infeed and discharge interlocks standard
- Large, legible ID tags permanently riveted, not glued

## Options available include:

- Larger ranges available
- Bar code readers
- Servo product laning
- Custom infeed systems
- Tray stacking on discharge

## Other Serpa Packaging Solutions:

### Cartoning:

- Intermittent Motion
- Continuous Motion
- Vertical
- Horizontal
- Single or Multiple Sleeviers
- Manual Load

### Case Packing:

- Case Erecting/Closing
- Semi-Automatic
- Bottom Load
- Wraparound
- Endload or Side Load
- Trays

### Systems:

- Line Integration
- Robotic loading
- Custom Product Handling

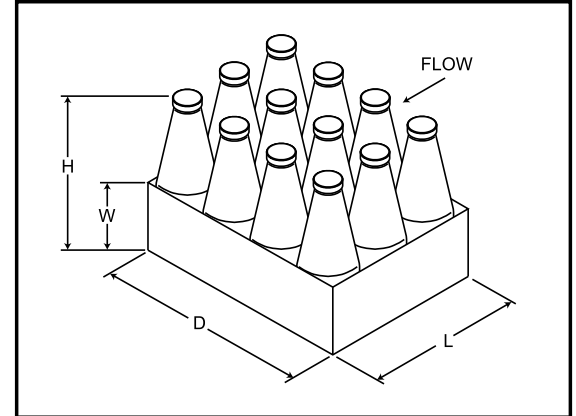

Case Range	Length	Width	Depth	Height	Speed
Minimum	6"	1 1/2"	11"	-	-
Maximum	10"	4"	18"	8"	50 TPM

## Products Include:

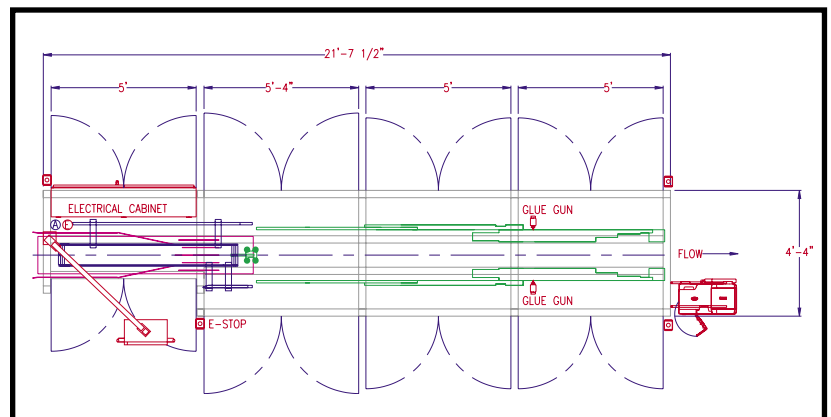

STANDARD RANGE FLOOR PLAN SHOWN

**SERPA**  
PACKAGING SOLUTIONS

At Serpa Packaging Solutions, we're designing extraordinary things!

SERPA PACKAGING SOLUTIONS • 7020 W. Sunnyview Ave., Visalia, CA 93291

TEL: 559.651.2339 • FAX: 559.651.2345

www.serpapackaging.com • EMAIL: sales@serpapackaging.com

Due to our continuous product improvement philosophy, specifications are subject to change without notice.

