

P300

BALCONY CASEPACKER

A high-speed casepacker that is totally accessible from the operator side... including the load station!



- All Servo Driven
- Balcony Design
- Compact Footprint
- All Belt Drives - low noise, longer life
- Unique Positive Dual Vacuum Case Erector (Patent Pending)
- Extremely Fast and Accurate Changeover - less than 5 minutes
- Telescoping Funnel - accurate product loading
- Low Maintenance - easy access to all components provides for easy maintenance
- User Friendly - fewer parts to time in
- Hot Glue or Tape Sealing
- **Validation Made Easy**

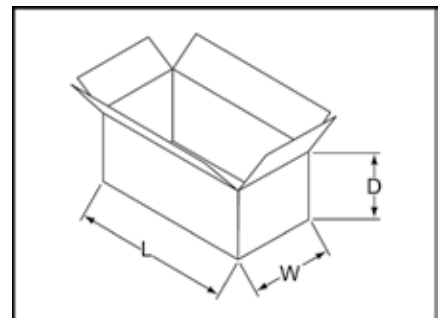

Case Range	Length	Width	Depth
Minimum	6" 152.4 mm	5" 127 mm	4.5" 114.3 mm
Maximum	20" 508 mm	13" 330.2 mm	13" 330.2 mm

Larger Ranges Available

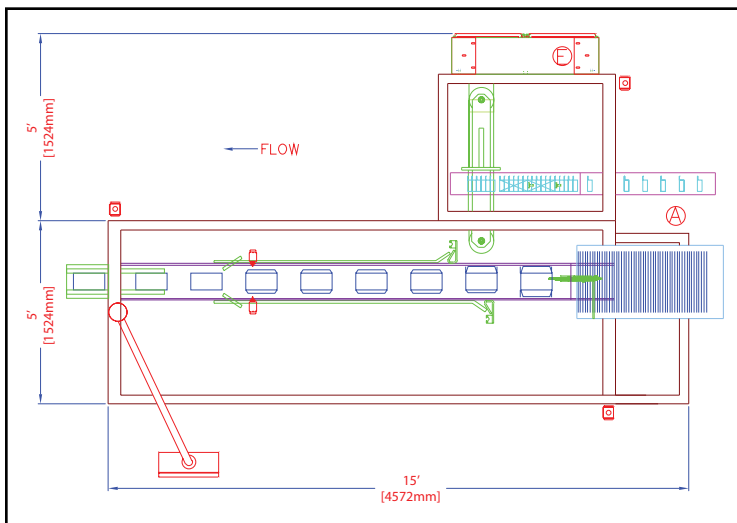

Standard Range Floorplan

SERPA
PACKAGING SOLUTIONS
 7020 W. Sunnyview Ave. • Visalia, CA 93291
 TEL: 559.651.2339 • FAX: 559.651.2345
 sales@serpapakaging.com
 www.serpapakaging.com