

P320

WRAPAROUND CASEPACKER

A high-speed wraparound casepacker that is totally accessible from the operator side...including the load station!



- All Servo Driven
- Balcony Design
- Compact Footprint
- All Belt Drives - low noise, longer life
- Unique Positive Dual Vacuum Case Erector (Patent Pending)
- Extremely Fast and Accurate Changeover - less than 15 minutes
- Telescoping Funnel - accurate product loading
- Low Maintenance - easy access to all components provides for easy maintenance
- User Friendly - fewer parts to time in
- Hot Glue Sealing
- **Validation Made Easy**

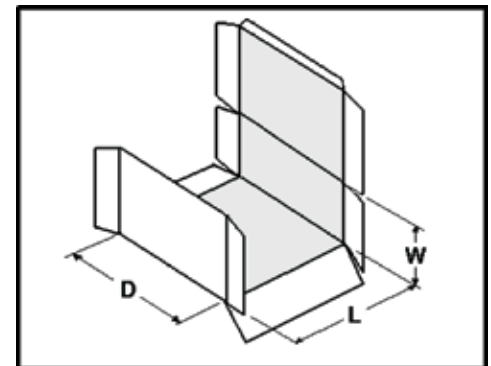

Case Range	Length	Width	Depth
Minimum	5"	5"	5"
Maximum	18"	14"	24"

Larger Ranges Available

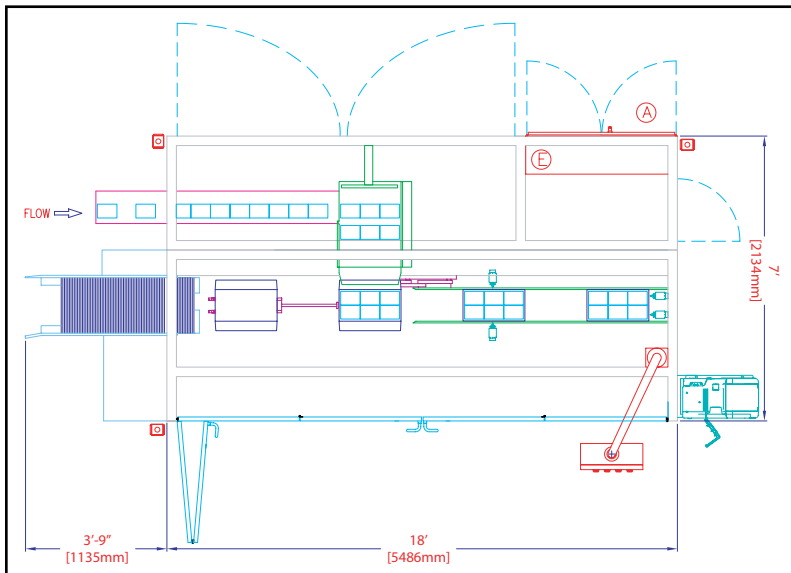

Standard Range Floorplan

SERPA
PACKAGING SOLUTIONS
 7020 W. Sunnyview Ave. • Visalia, CA 93291
 TEL: 559.651.2339 • FAX: 559.651.2345
 sales@serpapakaging.com
 www.serpapakaging.com